

Study on Reactive Non-thermal Plasma Process combined with Metal Oxide Catalyst for Removal of Dilute Trichloroethylene

Sang-Bo Han^{1,a}, Tetsuji Oda², Jae-Youn Park³, Sang-Hyun Park³, and Hee-Seok Koh³

Abstract

In order to improve energy efficiency in the dilute trichloroethylene removal using the nonthermal plasma process, the barrier discharge treatment combined with manganese dioxide was experimentally studied. Reaction kinetics in this process was studied on the basis of final byproducts distribution. Decomposition efficiency was improved to about 99 % at the specific energy of 40 J/L with passing through manganese dioxide. C=C π bond cleavage of TCE substances gave DCAC, which has the single bond of C-C through oxidation reaction during the barrier discharge plasma treatment. Those DCAC were broken easily in the subsequent catalytic reaction due to the weak bonding energy about 3 ~ 4 eV compared with the double bonding energy in TCE molecules. Oxidation byproducts of DCAC and TCAA from TCE decomposition are generated from the barrier discharge plasma treatment and catalytic surface chemical reaction, respectively. Complete oxidation of TCE into CO_x is required to about 400 J/L, but CO₂ selectivity remains about 60 %.

Key Words : Barrier discharge, Trichloroethylene, Manganese dioxide

1. INTRODUCTION

Nonthermal plasma technologies in the treatment of gaseous pollutants have investigated by many researchers[1-16]. Recently, nonthermal plasma technologies in the environmental application showed a tendency to combine with catalysts for improving energy efficiency. In the study of acetaldehyde removal[1], removal efficiency decreased with increasing the oxygen content about over 5 %. Comparison of reactor

types such as BaTiO₃ filled SUS and GL reactors (barrier (=glass) discharge reactor) have been experimented by Ogata et al.[2]. They also investigated the effects of the coexistence conditions of pollutants such as benzene, toluene, and o-xylene related with background gases and byproducts distribution. Krasnoperov et al.[3] reported the kinetic studies on the destruction of hydrocarbons and other pollutants using the dielectric barrier discharge reactor, they divided those substances into two categories related with the ionization energy level of substances. In addition, Penertrate et al.[4,5] had reported that the important factor in air conditions is the effective transfer of electrical energy into energetic electrons, because the low energy of electrons is consumed largely for the vibrational excitation of N₂ molecules and the dissociation of O₂ molecules.

Especially, chlorine contained-VOCs (Volatile Organic Compounds) such as trichloroethylene (TCE; C₂HCl₃), perchloroethylene (PCE C₂Cl₄),

1. Power Facilities Diagnosis Group, Korea Electro-technology Research Institute
(Seongju-dong, Changwon-si, Gyeongnam 641-120, Korea)

2. Department of Electrical Engineering, The University of Tokyo

3. Department of Electronic and Electrical Engineering, The University of Kyungnam

a. Corresponding Author : sbhan@keri.re.kr

접수일자 : 2005. 10. 10

1차 심사 : 2005. 12. 19

심사완료 : 2006. 1. 19

chloroform (CHCl_3), and carbon tetrachloride (CCl_4) should be fixed or removed before releasing to our environment because of its toxicity on our human being and bad sources to our environments.

In order to decompose dilute TCE in few hundreds ppm, Futamura et al.[6] had reported the detailed identification of volatile byproducts with ferro-electric pellet's filled plasma reactor for the investigation of the ambient gas effect. However, the distribution is different with this study, which might be caused the difference of reactor type. In addition, MILL et al.[7] and Hakoda et al.[8] reported the oxygen concentration, the effects of humidity, and byproducts variation on the consumption power (Doses) using the electron beam process. Oda et al. had also reported on the catalytic effects (V_2O_5 , WO_3 , and TiO_2) for the effective decomposition of dilute TCE with catalyst's filled barrier discharge reactor[9].

In this work, manganese dioxide (MnO_2) is used for its high ability on ozone decomposition. Related with kinetics of ozone decomposition at some impregnated catalysts, Einaga et al. reported that catalytic activities depend strongly on reaction conditions and catalyst's composition[10].

The objective of the present work is to improve energy efficiency combined with catalysts at the downstream of the barrier discharge reactor. Reaction kinetics in this process was studied on the basis of final byproducts distribution related with the specific energy density (SED).

2. EXPERIMENT

2.1 Experimental analysis

Concentration of TCE-contaminated synthesized air was adjusted by injecting liquid TCE with a micro-syringe pump. Metal oxide catalysts of manganese dioxide (MnO_2 25 g less than 3 mm length) filled in teflon tube (I. D.: 8 mm, filled zone: 250 mm) is arranged at the downstream of the barrier discharge reactor by inserting into quartz tube for temperature control.

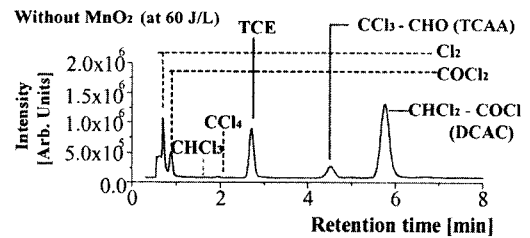

(a) Byproducts identification for the qualitative analysis

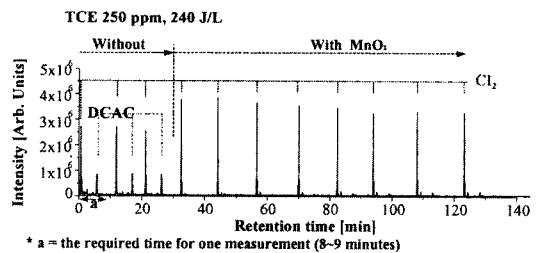

(b) Temporal variation of byproducts on working time at 240 J/L

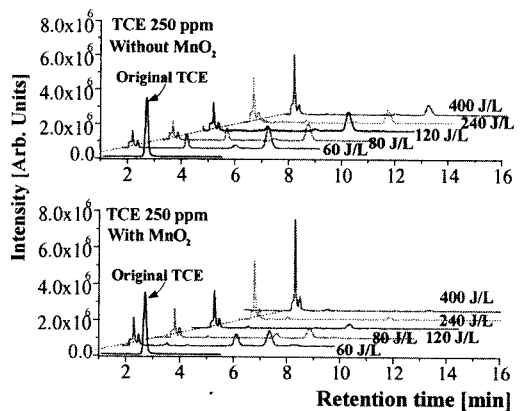

(c) Byproducts variation as a function of SED from GCMS

(Data with MnO_2 in the lower parts are abstracted from the final results in each measurement such as the saturated conditions.)

Fig. 1. Example of GC-MS result for the qualitative analysis on byproducts distribution and temporal variation of byproducts.

Specific surface area of manganese dioxide (Pyrolusite β - MnO_2) was $12.14 \text{ m}^2/\text{g}$. GCMS-QP5050A (Shimadzu Co.) with a wide-bore

capillary column BTX-200 (length: 30 m, inner diameter: 30 μm) is used to analyze chlorine contained-substances including TCE. Figure 1 showed an example for the qualitative analysis of byproducts in GCMS measurement.

FT-IR (Shimadzu Co., Prestige 21) was to measure CO, CO₂, N₂O, and other byproducts using long-path gas cell (Infrared Analysis Inc., optical path: ca. 2.4 m), which is possible to identify not only on-line byproducts variation, but also the calculation of absolute density using calibration curve of specified vibrational modes. In this experiment, peak area in transmittance was adopted to calculate the concentration with special care of CO peaks, which is overlapped with O₃ (2143.1 ~ 2041.3 cm^{-1}) and N₂O (2223.7 ~ 2041.3 cm^{-1}). Ozone meter (Okitronics, OZM-700G) and chemical luminescence NO_x gas analyzer (Shimadzu Co., NOA-7000) were used for the analysis of byproducts distribution.

2.2 Experimental procedure and plasma reactor

2.2.1 Experimental procedure

TCE-contaminated air was treated firstly in the barrier discharge plasma reactor. After that, remnant TCE and other toxic-discharge byproducts were processed at catalysts of manganese dioxide under the ambient temperature 25 °C. At the first time in each measurement, humidity was removed by flowing Ar gas (1 L/min) for about 100 minutes at 120 °C (± 3 °C). It prevents the deterioration of catalysts such as contamination, and the change of H₂O peaks at catalysts was identified with on-line FTIR measurement. After this procedure, temperature was naturally down to room temperature under the continuous flowing Ar gas, it was required for 40–50 minutes. It is considered that the initial conditions of catalyst is one of the important parameters to acquire a reproducible results and the high reliability.

2.2.2 Characteristics of plasma reactor

The barrier discharge reactor is composed of a quartz tube and a stainless steel bolt as shown in Fig. 2. The inner diameter of a quartz

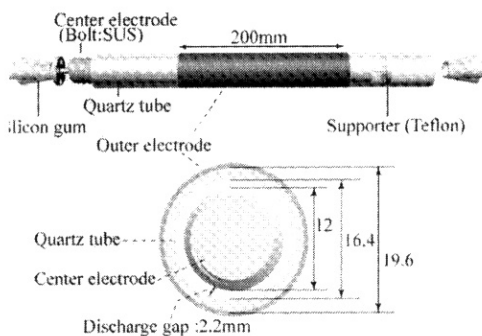
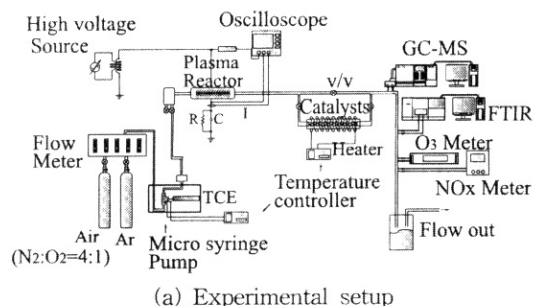
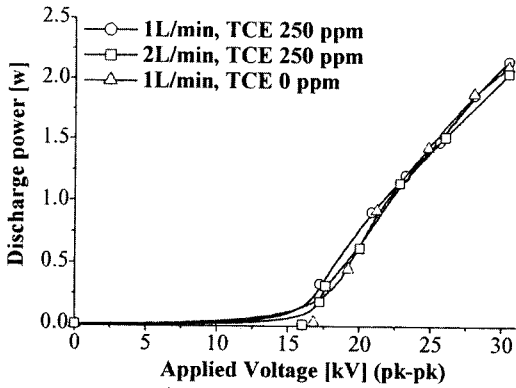

Fig. 2. Schematics of experimental setup and the barrier discharge reactor.

tube is 16.4 mm with thickness 1.6 mm, and the diameter of the discharge electrode is 12 mm. The discharge region is long about 200 mm, and the discharge gap was 2.2 mm. A commercial AC high-voltage source (50Hz) was used as a power source. The consumption power as a net discharge power was measured with applying Lissajous-Figure method (V-Q figure)[11].

The applied high voltage and the induced voltage at capacitor (0.67 μF) connected into the plasma reactor in series were measured for the calculation of the discharge power with a digital oscilloscope (TDS 3052, Tektronics). Discharge current was also detected with a commercial current monitor (Pearson Inc., Model No. 2878). In this reactor, discharge was initiated at the edge of the bolt-shape electrode due to the higher electric field than others. In general, the dielectric barrier discharge reactor is selected for suppressing thermal arc in each discharge. This



(a) The change of discharge power Vs. the applied voltage

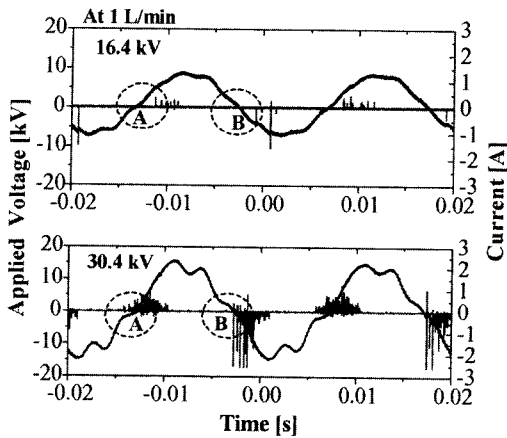

(b) Waveform of the applied voltage and discharge current

Fig. 3. The change of discharge power and the discharge waveform.

reactor type is usually made by inserting the dielectric barrier materials at both or one side of electrodes. Individual discharges were terminated automatically by the accumulation of opposite charges on the dielectric surface during each discharge, which is an important nature of this reactor as the low temperature process and the low consumption power. These discharge characteristics was reported by many researchers and find elsewhere[4,5]. Figure 3 showed that discharges took place when the applied voltage was zero. It is clear that charge deposition on the

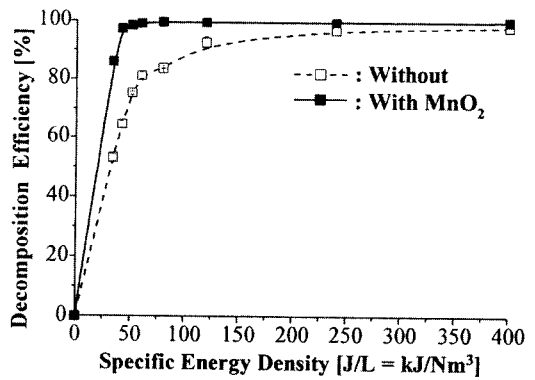

(a) Decomposition efficiency of TCE

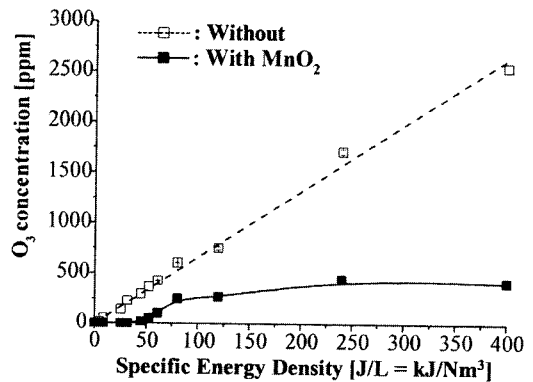

(b) The change of ozone concentration

Fig. 4. Decomposition efficiency of TCE and the change of ozone concentration Vs. SED.

barrier materials is affected to the consecutive discharge in next half cycle of the applied voltage. Discharge was initiated from 16.5 kV as shown in Fig. 3(a) and it occurred until the time variation of the applied voltage (dV/dt) became zero at both of the positive and negative polarity in the center electrode. As increasing the applied voltage up to 30 kV, discharge occurs effectively as shown in Fig. 3(b) marked with A and B.

3. EXPERIMENTAL RESULTS

3.1 Dependence on the specific energy density

In Fig. 4, decomposition efficiency of TCE versus SED is improved to about 99 % with

passing through manganese dioxide at 40 J/L. When plasma processed gas did not pass through manganese dioxide, decomposition efficiency about 99 % was attained at 240 J/L. From this result, the barrier discharge plasma treatment combined with manganese dioxide is an effective approach for decreasing the energy consumption. In addition, O₃ increased linearly with enhancing the specific energy density during the plasma treatment. Ozone is decomposed largely with passing through manganese dioxide as shown in Fig. 4(b).

Figure 5 shows the dependence of byproducts distribution on the specific energy density in cases of without and with manganese dioxide.

Main chlorine contained-byproducts are DCAC (Dichloro-acetylchloride, CHCl₂-COCl), TCAA (Trichloro-acetaldehyde, CCl₃-CHO), and Cl₂, it showed using the value of relative peak areas on the TCE initial concentration. When the plasma processed gas did not pass with catalysts, DCAC increased about 0.55 at below 60 J/L, but it decreased slightly with increasing SED. With passing through catalyst, DCAC decreased about a half upto 60 J/L. It is ascribed that DCAC decomposed through catalytic surface chemical reactions. At the same time, Cl₂ concentration and CO_x yield increased largely with passing through catalysts. Based on these results, oxygen species generated from ozone decomposition at catalysts enhanced the oxidative chemical reaction to increase Cl₂ and CO_x concentration as shown in Fig. 5(a) and 5(b). COCl₂, CHCl₃, CCl₄, and C₂HCl₅ were detected small as well.

In the case of TCAA distribution, TCAA did not increase largely in the plasma treatment only. However, but it showed a maximum value at 20 J/L with passing through catalysts. From this result, TCE was oxidized into TCAA at catalysts due to chemical reactions during ozone decomposition. It is likely that the role of oxygen species in the plasma treatment and the subsequent catalytic reaction can be identified from byproducts distribution. Oxidation byproducts of DCAC and TCAA are generated from the barrier

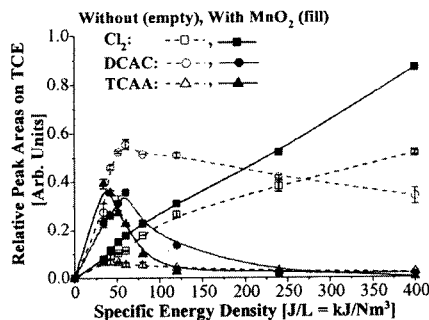

(a) The change of chlorine contained-byproducts

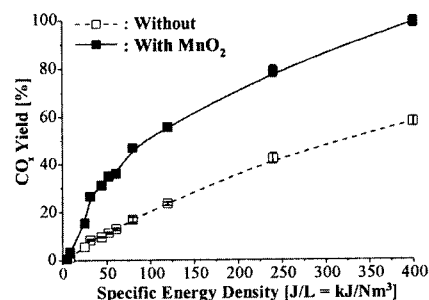

(b) The change of CO_x yield (%)

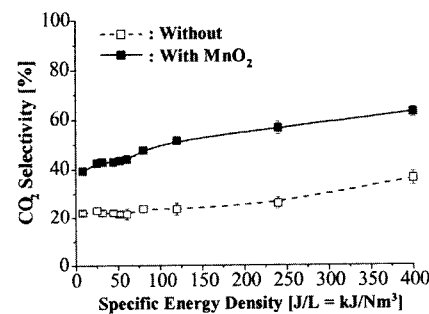

(c) The change of CO₂ selectivity

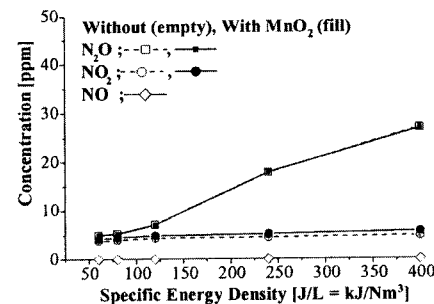

(d) The change of N_xO_y (NO, NO₂, and N₂O)

Fig. 5. The change of byproducts distribution Vs. SED.

discharge plasma treatment and catalytic surface chemical reaction, respectively. Namely, oxygen species for generating TCAA and DCAC from TCE induced different reaction kinetics. Related with the origin of oxygen species, oxygen species such as $O(^1D)$ and $O(^3P)$ exist in this plasma treatment for generating ozone molecules[5], and another oxygen species might occur during ozone decomposition at catalysts as well. The subsequent chemical reaction at catalysts increased CO and CO_2 concentration by the oxidation reaction. In this result, ozone decomposition at catalysts is assumed to give oxygen species for enhancing energetic chemical reactions. The complete oxidation of TCE and discharge byproducts into CO_x was required to about 400 J/L under this experimental conditions at 250 ppm, but CO_2 selectivity remains about 60 % as shown in Fig. 5(b) and 5(c).

Figure 5(d) shows the change of N_xO_y (NO , NO_2 , and N_2O) as a function of SED. NO_2 concentration was below 5 ppm in any cases, and N_2O increased about 30 ppm at 400 J/L. However, concentrations of NO_x and N_2O were not changed with passing through catalysts. It can be assumed that oxygen species at catalysts are not able to dissociate those species due to lower energy than their bonding energies.

3.2 Dependence on the initial TCE concentration

Figure 6 shows the relationship between TCE decomposition efficiency and the initial TCE concentration. Since the variation of ozone concentration is important parameter to know the catalytic effect exactly, the variation of ozone concentration with working time reached the saturated conditions at the above 100 min.

The lower initial TCE concentration existed in the main gas stream (= working gas), the larger ozone was generated from the barrier discharge plasma treatment. Since O radicals in the discharge region are the fundamental species for the generation ozone, those O radicals are consumed to generate ozone and oxidize TCE into DCAC. As TCE concentration decreased, O radicals are affected to increase ozone concentration than the high TCE concentration.

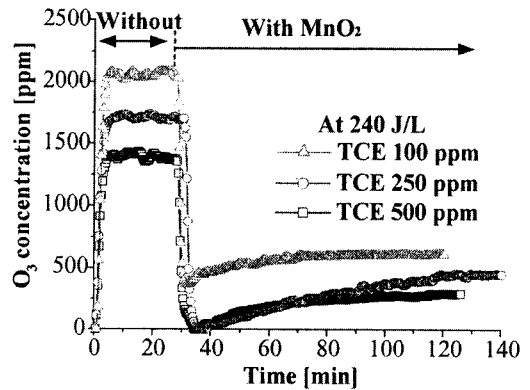

(a) Variation of ozone concentration with working time

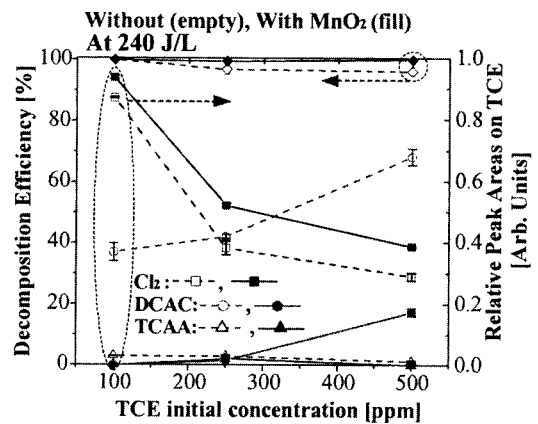

(b) The change of chlorine contained-byproducts

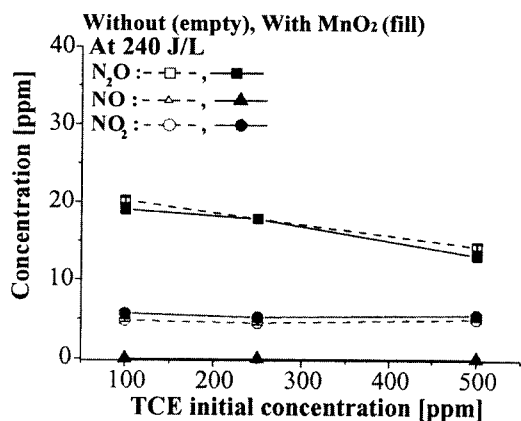

(c) The change of N_xO_y (NO , NO_2 , N_2O)

Fig. 6. The change of byproducts distribution Vs. initial TCE concentration.

In cases of 250 and 500 ppm, TCE decomposition efficiency was about 97 % without passing through manganese dioxide. The remaining TCE decomposed completely with passing through MnO₂ in any cases. Relative ratio of Cl₂ increased with decreasing the initial TCE concentration in the barrier discharge plasma treatment, and it more increased than before with passing through catalyst. It can be confirmed that almost DCAC decomposed into Cl₂ and CO_x at the below 250 ppm, but a little was resided at 500 ppm even though 100 % decomposition efficiency of TCE. In this study, this system of plasma reactor and catalyst are adequate to the below 250 ppm at 240 J/L. Therefore, those combined system with manganese dioxide are very desirable to oxidize byproduct into small molecules such as Cl₂ and CO_x.

4. EXPECTED CHEMICAL REACTIONS

In the plasma treatment, chlorine radical chain reaction is considered as a plausible decomposition mechanism of TCE. Chlorine radicals might be generated from collisions of electron or excited species with TCE and other chlorine contained-byproducts. Substances marked with rectangular in Fig. 4 are main byproducts detected in this experiment. It was only limited to radical reactions without considering ionic reactions.

Although many researchers had been suggested those reaction kinetics such as photo-chlorination (Bertrand et al., 1968[15]), the ion (Cl⁻) chain reactions (Nichipor et al., 2002[18]), radical and ionic reaction mechanisms (Futamura et al. 1997[10]), chemical reactions in plasma physics have not been fully described until now.

L. Bertrand et al. studied about the chlorine-photosensitized oxidation of TCE with regards to the structural position of chlorine atom. From their results, CHCl₂COCl (DCAC), COCl₂, HCl, CO₂, and other substances were detected as the reaction byproducts. ·CCl₂CHCl₂ radical was considered to lead final byproducts of DCAC as well. Although COCl₂ was detected through the possible oxidation reaction in their works, it generates a little in this work. However, HCl did

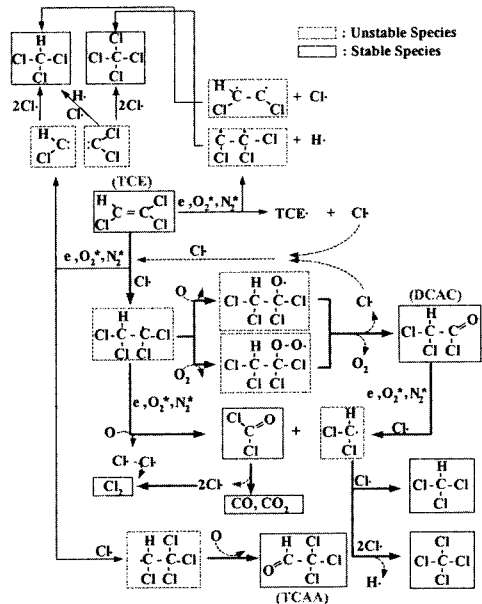

(a) Chemical reaction in the plasma region

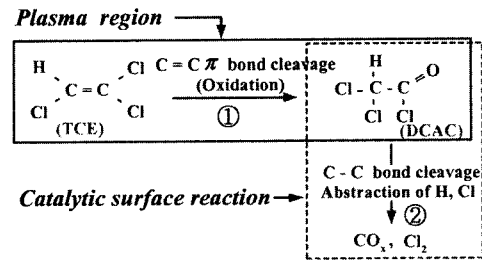

(b) The expected chemical reactions

Fig. 7. Expected chemical reaction in the plasma region and the subsequent reaction at manganese dioxide.

not generate unexpectedly. The subsequent catalytic reactions after the barrier discharge plasma treatment could be expected from increasing CO_x and Cl₂ concentration, when plasma treated gases were passed through manganese dioxide.

Oxygen radicals from dissociation of the chemisorbed ozone might be generated at manganese dioxide, and reactive chlorine contained-intermediates such as Cl₂, ClO, ClO₂, and Cl radicals might be generated as well.

Those reactive species might cause energetic chemical reactions to increase CO_x and Cl_2 concentration as the final byproducts. Briefly, these reactions are likely that C=C π bond cleavage in TCE gave DCAC (single bond, C-C) through oxidation reaction during the barrier discharge plasma treatment. Henceforth, those DCAC were broken easily in the subsequent catalytic reaction due to the weak bonding energy (Approx. 3 ~ 4 eV[19,20]) compared with the double bonding of TCE (C=C). This reaction kinetics was depicted briefly in Fig. 7(b).

Since the slight oxidation of TCE into DCAC has a possibility to cause misunderstand as the increase of the decomposition efficiency. Authors are suggested that final byproducts distribution from TCE removal should be analyzed thoroughly in this plasma process.

5. CONCLUSION

The barrier discharge plasma treatment combined with ozone decomposition catalysts was studied experimentally for decomposing dilute TCE, due to ozone generation in the barrier discharge plasma process under the aerated conditions. Experimental results are summarized as follows.

- 1) Decomposition efficiency was improved to about 99 % at 40 J/L with passing through manganese dioxide. The barrier discharge plasma treatment combined with manganese dioxide is likely to an effective approach for decreasing the energy consumption.
- 2) The required specific energy density for the highest oxidation of TCE into CO_x and Cl_2 was about 400 J/L.
- 3) The lower initial TCE concentration existed in the main gas stream (= working gas), the larger ozone was generated from the barrier discharge plasma treatment. Almost DCAC decomposed into Cl_2 and CO_x at the below 250 ppm, but a little was resided at 500 ppm even though 100 % decomposition efficiency of TCE.
- 4) C=C π bond cleavage in TCE gave DCAC (single bond, C-C) through oxidation reaction during the barrier discharge plasma treatment. Those DCAC were broken easily in the subsequent catalytic reaction due to the weak bonding energy about 3 ~ 4 eV compared with the double bonding energy in TCE molecules.
- 5) Chlorine radical chain reaction is considered as a plausible decomposition mechanism in the barrier discharge plasma treatment. Decomposition mechanisms of TCE and other discharge byproducts at catalysts were briefly reviewed.

ACKNOWLEDGEMENTS

The authors wish to thanks Professor T. Oda and Associate researcher T. Takahashi for their valuable advices and comments at the University of Tokyo in Japan. This work is supported by the research program at the University of Kyungnam.

REFERENCES

- [1] H. M. Lee and M. B. Chang, "Removal of Gaseous Acetaldehyde via a Silent Discharge Reactor packed with Al_2O_3 Beads", ISNPT-3, p. 99, 2001.
- [2] A. Ogata, D. Ito, and K. Mizuno, "Effect of coexisting components on aromatic decomposition in a packed-bed plasma reactor", Appl. Catal. A, General 236, p. 9, 2002.
- [3] L. N. Krasnoperov and L. G. Krishtopa, "Kinetic Study on the Destruction of Hydrocarbons, NO_x and SO_{Xin} Dielectric Barrier discharge", ISNPT-3, p. 23, 2001.
- [4] B. Eliasson and U. Kogelschatz, "Nonequilibrium volume plasma chemical processing", IEEE Trans. Plasma Sci., Vol. 19, No. 6, p. 1063, 1991.
- [5] B. Eliasson, M. Hirth, and U. Kogelschatz, "Ozone synthesis from oxygen in dielectric barrier discharges", J. Phys. D: Appl. Phys., Vol. 20, No. 11, p. 1421, 1987.

- [6] S. Futamura and T. Yamamoto, "Byproducts identification and mechanism determination in plasma chemical decomposition of trichloroethylene", *IEEE Trans. Indus. App.*, Vol. 33, No. 2, p. 447, 1997.
- [7] T. Mill, M. Su, C. C. D. Yao, S. M. Matthews, and F. T. S. Wang, "E-beam treatment of trichloroethylene-air mixtures products and rates", *Radiat. Phys. Chem.*, Vol. 50, No. 3, p. 283, 1997.
- [8] T. Hakoda, S. Hashimoto, and T. Kojima, "Effect of water and oxygen contents on the decomposition of gaseous trichloroethylene in air under electron beam irradiation", *Bull. Chem. Soc. Jpn.*, Vol. 75, p. 2177, 2002.
- [9] T. Oda, K. Yamaji, and T. Takahashi, "Decomposition of dilute trichloroethylene by nonthermal plasma processing gas flow rate, catalyst, and ozone effect", *IEEE Trans. Indus. App.*, Vol. 40, No. 2, p. 430, 2004.
- [10] H. Einaga and S. Futamura, "Comparativestudy on the catalytic activities of Alumina-supported metal oxides for oxidation of benzene and cyclohexane with ozone", *React. Kine. Catal. Lett.*, Vol. 81, No. 1, p. 121, 2004.
- [11] I. Nagao, M. Nishida, K. Yukimura, S. Kambara, and T. Maruyama, "NO_x removal using nitrogen gas activated by dielectric barrier discharge at atmosphere pressure", *Vacuum* 65, No. 3, p. 481, 2002.
- [12] B. Dhandapani and S. Ted Oyama, "Gas phase ozone decomposition catalyst", *App. Catal. B, Environ.*, Vol. 11, No. 2, p. 129, 1997.
- [13] K. Urashima and J. S. Chang, "Removal of VOCs from air streams and industrial flue gases by non-thermal plasma technology", *IEEE Trans. Dielec. and Electric. Insul.*, Vol. 7, No. 5, p. 602, 2000.
- [14] D. Li, D. Yakushiji, and S. Kanazawa, "Removal of VOC using a Streamer Corona Discharge Reactor with Catalyst", *ISNPT-3*, p. 94, 2001.
- [15] J. J. Lowke and R. Morrow, "Theoretical analysis of removal of oxides of sulphur and nitrogen in pulsed operation of electrostatic precipitators", *IEEE Trans. Plasma Sci.*, Vol. 23, No. 4, p. 661, 1995.
- [16] H. H. Kim, K Takashima, S Katsura, and A Mizuno, "Low-temperature NO_x reduction processes using combined systems of pulsed corona discharge and catalysts", *J. Phys. D: Appl. Phys.*, Vol. 34, No. 4, p. 604, 2001.
- [17] L. Bertrand, J. A. Franklin, P. Goldfinger, and G. Huybrechts, "The point of attack of a chlorine atom on trichloroethylene", *J. Phy. Chem.*, Vol. 72, No. 11, p. 3926, 1968.
- [18] H. Nichipor, E. Dashouk, S. Yacko, A. G. Chmielewski, H. Nichipor, Z. Zimek, and Y. Sun, "Chlorinated hydrocarbons and PAH decomposition in dry and humid air by electron beam irradiation", *Radia. Phy. Chem.*, Vol. 65, No. 4, p. 423, 2002.
- [19] D. R. Lide, "CRC Handbook of Chemistry and Physics", 83rd Edition(hardcover), 2002-2003.
- [20] T. Yamamoto, "VOC decomposition by nonthermal plasma processing a new approach", *J. Electros.*, Vol. 42, No. 1, p. 27, 1997.