

## Measurement of Ar Temperature of Hollow Cathode Discharge Plasma

Jun-Hoi Lee<sup>1,a</sup>, Jae Soo Shin<sup>1</sup>, Sung Jik Lee<sup>2</sup>, and Min Soo Lee<sup>3</sup>

### Abstract

The plasma temperature of Ar gas in hollow cathode discharge were measured. This is done by measuring the line profile of the  $1s_8-2p_8$  transition in Ar, using a single frequency diode laser. Low power diode lasers have been successfully used for investigation of the line profiles of Ar transitions in hollow cathode discharges. It turns out that the plasma temperature of Ar is 640~783 K in the discharge current range at 7~10 mA.

**Key Words** : Optogalvanic effect, Plasma temperature, Hollow cathode

### 1. INTRODUCTION

Low power diode lasers in a visible range have been successfully used for investigation of the line profiles of Ne and He transitions in hollow cathode discharge plasmas. A hollow cathode discharge (HCD) plasma[1] is widely used as an atomic vapor or emission source for most elements in the Periodic Table[2]. Because of its high signal-to-noise ratio and relatively simple experimental setup, the optogalvanic (OG) detection method in HCD has been recognized as a powerful technique for several spectroscopic studies and plasma discharge diagnostics[3-5]. It is necessary to take great care in utilizing the OG line shapes for measuring spectroscopic quantities because the OG line shapes may be different from the absorption (Gaussian or Voigt) line shapes[6-9].

The OG effect technique was developed for the purpose of laser spectroscopy. When a self-sustained gaseous discharge is illuminated by radiation resonant with an atomic or molecular transition of the elements within it, a change in its electrical properties occurs. This change is observed as an increase or decrease in the conductivity of the discharge and is known as the optogalvanic effect.

In this report, temperature of HCD plasma at low discharge current of 10 mA is studied by illumination a continuous wave diode laser tuned to the resonant frequency of the Ar metastable transition. A diode laser is an appropriate light source for studying the Ar discharge because most lines for  $1s-2p$  transitions of Ar are located in the near infrared wavelength region [10]. Laser induced fluorescence can be used as a diagnostic tool for fundamental investigations of glow discharge plasma. Laser interaction provides an excellent method for spatially profiling plasma species.

The plasma has been widely used for semiconductor manufacturing in the field of plasma application such as dry etching, plasma enhanced chemical vapor deposition, and so on. In the etching process, a lower temperature is

1. Department of Advanced Materials Science, Daejeon University

(96-3 Yongun-dong, Dong-gu, Daejeon)

2. Department of Physics, Chungnam University

3. Applied Optics and Electromagnetic, Hannam University

a. Corresponding Author : jh0817@dju.ac.kr

접수일자 : 2004. 12. 8

1차 심사 : 2005. 1. 3

심사완료 : 2005. 3. 14

required to obtain high quality semiconductor devices particularly when etching with high selectivity is required. The HCD plasma system of the present study was used in the etching study of silicon surface[11].

In this experiment, the measurement of plasma temperature of hollow cathode discharge using OG line shapes has been performed in a 801.479 nm ( $1s_5 - 2p_8$ ) metastable transition of Ar.

## 2. EXPERIMENTAL

The experimental setup is shown schematically in Fig. 1. A commercial HCD tube (Cathodeon Ltd., model 3QQAY/Gd) was used in the experiment. Each one consists of cylindrical hollow cathode inner diameter of 2 mm and length of 20 mm with two-ring anodes and contains Ar gas at pressure of about 3 Torr. The discharge current was approximately 7~10 mA.

The discharge was produced by a high voltage power supply (Bertan Associate, Inc., model series 105). Current limiting resistors of 10 k $\Omega$  were used for each anode and the OG signal was detected by blocking the dc voltage using a coupling capacitor of 0.01  $\mu$ F. We used a single-mode diode laser system which has center wavelength of 810 nm (Environmental Optical Sensor, Inc., model EUC-2010). An anamorphic prism pair and iris diaphragm of 0.5 mm diameter were used to make an appropriate laser beam shape. A small part of the laser beam was split off by using a thin glass plate and an anamorphic prism pair and iris diaphragm of 0.5 mm diameter were used to make an appropriate laser beam shape. A small part of the laser beam was split off by using a thin glass plate and was sent to a confocal Fabry-Perot etalon (TecOptics, model SA-300). The Fabry-Perot etalon was used to measure the line width for optogalvanic signals.

The laser beam path of 0.5 mm diameter was carefully adjusted to pass through the center of the negative glow region inside the cathode. The

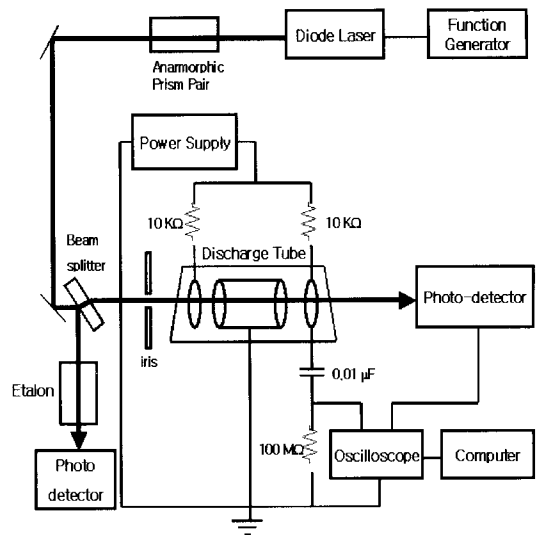

Fig. 1. Experimental setup.

laser beam power in front of the HCD tube was 1 mW and more than 90 % of the input power was transmitted through the HCD tube with the discharge off. With the laser wavelength fixed at the center of a transition line of Ar, the OG signal was measured through a coupling capacitor of 0.01  $\mu$ F by using a digital oscilloscope (Hewlett Packard, model 54600B).

## 3. RESULTS AND DISCUSSION

In our experiment, the cylindrical cathode was open ended in both directions and was placed between two hollow anodes. The use of two anodes ensured that the whole length of the cathode bore was covered with a negative glow in the axial direction. On the other hand, the cathode dark space and negative glow region occupied the HCD mainly in the radial direction. These discharge regions were well defined visually by monitoring the appearance of the plasma emission, as shown in Ref.[12]. A sketch of the cylindrical hollow cathode used in the experiment is shown in Fig. 2. The hollow cathode represents a unique of dense and stable plasma generated due to the hollow cathode effect.

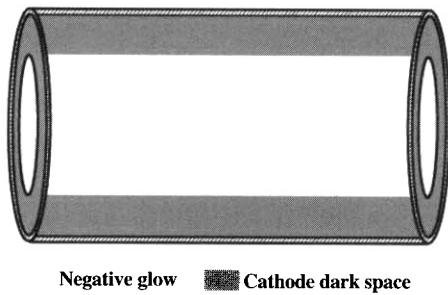

Fig. 2. A sketch of the cylindrical hollow cathode discharge. The cathode dark space and the negative glow region occupied in the radial direction. The laser beam passed through the central part.

This effect is based on oscillations of hot electron between repelling potential drop of cathode at opposite wall in the cathode when these walls are close to each other, so that they enable interactions of adjacent negative glow. Hence, the electron density increases in the negative glow. This design allows operation with the negative glow region tapped within the cathode cavity, reduced discharge sustaining voltage and enhanced electron multiplication.

The OG signal is a result of the discharge plasma conductivity variation caused by absorption of the radiation at a certain spectral transition of the plasma medium. To understand the reason for OG signals, let us consider the effect of light perturbation. When the laser beam is irradiated, two atomic processes can be generated by the perturbation of the population distribution among the relevant atomic levels. Laser excitation of metastable atoms causes the depletion of those atoms due to decay to the ground level via short-lived resonant levels ( $1s_2$ ,  $1s_1$ ) and results in a decrease in the conductivity. At the same time, laser excitation of metastable atoms to a higher level enhances the ionization due to collisions with electrons and results an increase in the conductivity. These two processes compete with each in generating OG signal.

A schematic diagram of the relevant energy

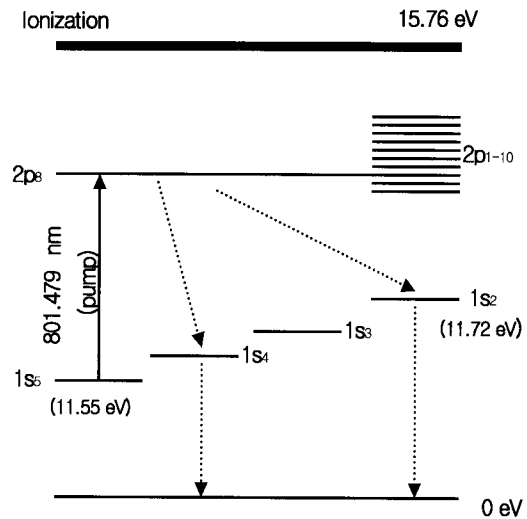
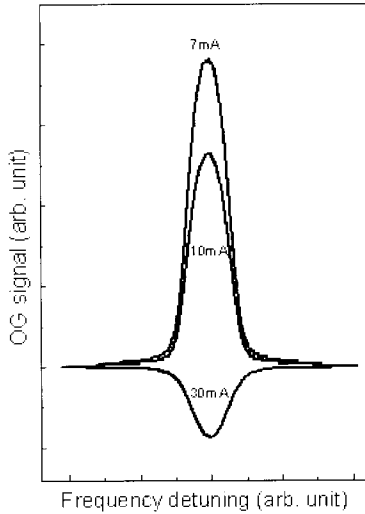

Fig. 3. Energy level diagram for the  $1s_i - 2p_j$  argon transitions studied in this work. Each electronic state is labelled by its Paschen notation.

levels[10] is shown in Fig. 3. The lowest excited electronic configuration of Ar consists of four  $1s_i$  ( $i=2-5$ ) levels. Two of these states, and are metastable. The state is quasi-metastable with a slight triple singlet mixing. The state is radiatively coupled with the ground state. The next excited configuration consists of the  $2p_j$  ( $j=1-10$ ) levels radiatively coupled to the levels. The OG signal is generated by the perturbation of the population distribution among atomic levels ( $1s-2p$ ) and subsequent relaxation processes[13].

A self-sustained oscillation, called the spontaneous oscillation, and damped oscillation are appeared in OG signal of the discharge voltage occurred at low discharge currents less than about 3 mA. In this case, OG line shapes different from the absorption line shapes. In the current range over 3 mA, the OG line shapes resemble those of absorption and are used to diagnose the characteristics of the discharge plasma. A typical line shapes at various discharge currents are shown in Fig. 4. As shown



**Fig. 4.** Oscilloscope trace of the optogalvanic line shapes. The optogalvanic line shapes resemble those of absorption.

in Fig. 5, the OG signal fits well to a Gaussian line shape and the Doppler line width of OG signal is 1.13 GHz at discharge current of 7 mA. The Doppler line widths of OG signal in Ar HCD are 1.13~1.25 GHz at discharge current 7~10 mA. The temperature of the plasma, T(K) can be calculated from the width of line shape, is given by

$$\Delta\nu_D = 7.16 \times 10^{-6} \sqrt{\frac{T}{M}} \nu_0 \quad (1)$$

where  $\Delta\nu_D$  is the Doppler broadened line width (FWHM),  $\nu_0$  is the center frequency of the transition,  $M$  is the mass of the atom[14]. The line width,  $\Delta\nu_D$ , was estimated from the line profile of the OG spectrum at 801.479 nm for Ar HCD. The precision of the line width measurement depends on the accuracy of the free spectral range of the frequency marker.

The measured the Doppler line width of OG line shapes and plasma temperatures of the Ar HCD are summarized in Table 1. The measured temperatures of Ar hollow cathode discharge are about 640 ~ 783 K at discharge current of 7~

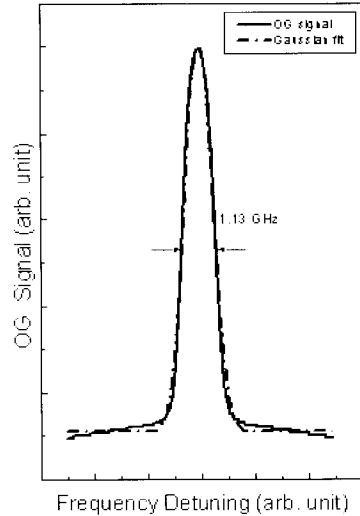

**Fig. 5.** The OG line shape at a current of 7 mA. It agrees with a Gaussian profile having a line width (FWHM) of 1.13 GHz.

**Table 1.** The Doppler line width measured by the OG line shapes and the plasma temperature of Gd/Ar HCD at various discharge currents.

Current (mA)	FWHM (GHz)	Temperature (K)
7	1.13	640
8	1.16	674
9	1.20	722
10	1.25	783

10 mA. This result agrees with the earlier experimental observation reported by Jonkers, Bakker, and Mullen[15]. They showed that the temperature of Ar gas is 810 K at discharge pressure of 133 Pa and RF power of 80 W.

#### 4. CONCLUSIONS

The plasma temperature of argon in hollow cathode discharge was investigated by the optogalvanic spectroscopy. It was found that the temperature was in the range of 600~800 K at discharge current range of 7~10 mA and

increased with increasing in the discharge current.

The optogalvanic line shapes resemble those of absorption and are used to diagnose the characteristics of the discharge plasma, example plasma temperature and line profiles. The measurement of the optogalvanic signal is demonstrated as complementary method to understand the characteristic of hollow cathode discharge plasma.

## REFERENCES

- [1] S. Caroli and O. Senofonte, "Glow Discharge Spectroscopies", Plenum Press, New York, Chap. 6, p. 215, 1993.
- [2] Hollow Cathode Lamps, catalog, Cathodeon Ltd., Nuffeld Road, Cambridge, CB4 1TW.
- [3] B. Barbieri, N. Beverini, and A. Sasso, "Optogalvanic spectroscopy", *Rev. Mod. Phys.*, Vol. 62, No. 3, p. 602, 1990.
- [4] M. B. Schulman and D. R. Woodward, "Plasma enhanced photo-emission as a discharge lamp discharge", *Appl. Phys. Lett.*, Vol. 55, No. 16, p. 1618, 1989.
- [5] C. P. Ausschnitt, G. C. Bjorklund, and R. R. Freeman, "Hydrogen plasma diagnostics by resonant multiphoton optogalvanic spectroscopy", *Appl. Phys. Lett.*, Vol. 33, No. 10, p. 851, 1978.
- [6] R. A. Keller, R. Engleman, Jr., and E. F. Zalewski, "Opto-galvanic spectroscopy in a uranium hollow cathode discharge", *J. Opt. Soc. Am.*, Vol. 69, No. 5, p. 738, 1979.
- [7] E. F. Zalewski, R. A. Keller, and R. Engleman, "Laser induced impedance change in a neon hollow cathode discharge. A mechanistic study", *Jr, J. Chem. Phys.*, Vol. 70, No. 2, p. 1015, 1979.
- [8] H. A. Bachor, P. J. Manson, and R. J. Sandeman, "Optogalvanic detection as a quantitative method in spectroscopy", *Optics Comm.*, Vol. 43, No. 5, p. 337, 1982.
- [9] D. M. Kane, "Optogalvanic signals generated in a neon positive column discharge by resonant chopped cw radiation at 588.2 nm", *J. Appl. Phys.*, Vol. 56, No. 5, p. 1267, 1984.
- [10] W. L. Wiese, M. W. Smith, B. M. Miles, "Atomic Transition Probabilities (sodium Through Calcium)", *Nat. Stand. Ref. Data Ser.*, *Nat. Bur. Stand.* 22, p. 187, 1969.
- [11] J. H. Lee, W. J. Lee, M. S. Choi, and J. S. Yi, "High density hollow cathode plasma etching for field emission display applications", *J. Information Display*, Vol. 2, No. 4, p. 1, 2001.
- [12] E. C. Jung, J. M. Lee, J. H. Lee, and H. Cho, "Anomalous optogalvanic line shapes of argon in a hollow cathode discharge", *J. Kor. Phys. Soc.*, Vol. 34, No. 3, p. 209, 1999.
- [13] J.-H. Lee, "The role of metastable atoms for optogalvanic signal generation in a neon negative glow discharge", *J. Phys. Soc. Jpn.*, Vol. 72, No. 5, p. 1107, 2003.
- [14] O. Auciello, D. L. Flamm "Plasma Diagnostics Volume I", Academic Press, Chap. 7, p. 387, 1989.
- [15] J. Jonkers, M. Bakker, and J. A. M van der Mullen, "Absorption measurements on a low pressure, inductively coupled, argon-mercury discharge for lighting purpose: 1. The gas temperature and argon metastable states density", *J. Phys. D: Appl. Phys.*, Vol. 30, p. 1928, 1997.