

고체전지용 $\text{Li}_x\text{V}_3\text{O}_8$ Composite 정극의 전기화학적 특성

11-9-10

Electrochemical Properties of $\text{Li}_x\text{V}_3\text{O}_8$ Composite Cathode for All-solid state Rechargeable Battery

김종욱*, 성창호*, 구할본* 박복기**

(Jong-Uk Kim, Chang-Ho Sung, Hal-Bon Gu, Bok-Kee Park)

요 약

본 논문에서는 고체 리튬 전지를 개발하기 위하여 poly(ethylene oxide) [PEO]에 LiClO_4 , poly(vinylidene fluoride) [PVDF] 및 가소제로 propylene carbonate [PC]와 ethylene carbonate [EC] 등을 혼합하여 고분자 전해질을 제조하였다. 또한 고체 리튬 전지용 정극으로써 우수한 특성이 기대되는 $\text{Li}_x\text{V}_3\text{O}_8$ 은 졸-겔법에 의해 합성하여 $\text{Li}_x\text{V}_3\text{O}_8/\text{SPE}/\text{Li}$ cell의 전기화학적 특성을 측정하였다. 고분자 matrix로 PEO와 PVDF를 혼합 사용한 결과 $\text{PEO}_4\text{PVDF}_4\text{LiClO}_4\text{PC}_5\text{EC}_5$ 고분자 전해질이 상온에서 $5.2 \times 10^{-3} \text{ S/cm}$ 의 높은 이온 전도도를 나타냈으며 리튬 이온 transference number는 0.3이었다. 졸-겔법에 의해 제조된 $\text{Li}_x\text{V}_3\text{O}_8$ 을 사용한 $\text{Li}_x\text{V}_3\text{O}_8/\text{SPE}/\text{Li}$ cell의 방전시 cell 저항이 방전 초기에는 미소한 증가를 하다가 방전 말기 전압인 2.0V에서 크게 증가하였다. $\text{Li}_x\text{V}_3\text{O}_8$ composite 정극의 첫번째 방전 용량은 295mAh/g이었으며 8번째 충방전 사이클부터 방전 용량이 안정화 되었고 15번째 방전 용량도 212mAh/g으로 고체 전지용 정극으로써 우수한 특성을 보였다.

Key Words(중요용어) : All-solid state rechargeable battery(고체전지), Conductivity(전도도), Sol-gel method(졸-겔법), Charge/discharge cycle(충방전 사이클)

1. Introduction

Polymer electrolytes were discovered by B. E. Fenton et al.¹⁾ in 1973. P. V. Wright et al.²⁾ then showed that complexes formed with PEO and alkali metal salts exhibit high ionic conductivity. Subsequently these complexes were proposed by M. B. Armand et al.³⁾ as polymer electrolyte for solid state battery and electrochemical device applications. Polymer electrolyte has provided the interesting possibility of developing new types of lithium battery, so-called lithium polymer

battery(LPB)⁴⁾, having thin layers. The LPB is an all-solid state system which consists of a lithium ion conducting polymer electrolyte and two lithium ion reversible electrodes. The LPB can be viewed as a suitable system for wide applications, from thin film batteries for microelectronics to electric vehicle batteries and load leveling batteries⁵⁾.

$\text{Li}_x\text{V}_3\text{O}_8$ is an interesting alternative to V_6O_{13} and V_2O_5 for use as the active material in lithium rechargeable batteries^{6),7)}. High initial capacities were reported for low rate discharges, the maximum lithium uptake corresponding to more than three addition Li per formula unit, giving a stoichiometric energy density in excess of 650Wh/kg⁸⁾.

This study is to research and develop $\text{Li}_x\text{V}_3\text{O}_8$ composite cathode with high energy density for

* : 전남대학교 공대 전기공학과
(광주광역시 북구 용봉동 300, Fax: 062-530-0077
E-mail : hbgu@orion.chonnam.ac.kr)
** : 전북산업대 전기공학과
1998년 2월 21일 접수, 1998년 7월 27일 심사완료

all-solid state rechargeable battery. In this work we report the conductivity and transference number of PEO/PVDF electrolytes and the interfacial resistance variation as a function of state of charge(SOC) and discharge capacity with cycling of $\text{Li}_x\text{V}_3\text{O}_8/\text{SPE}/\text{Li}$ cells.

2. Experimental

High molecular weight PEO(MW : 2×10^6), Li salt(LiClO_4), propylene carbonate(PC) and ethylene carbonate(EC) were purchased from Aldrich Co. PEO was dissolved in acetonitrile(ACN, Aldrich Co.) by 20wt% solution. LiClO_4 and PEO were dissolved in acetonitrile(Aldrich Co.), the ratio of EO/Li was 4, 6, and 8 (EO represents repeating unit of PEO), and addition of PC and EC was followed after that. Also, poly(vinylidene fluoride)[PVDF, EIF Autochem North America Inc.] were added to the PEO- LiClO_4 -PC-EC-ACN solution. The polymer electrolyte films were prepared by solution casting. After solvent evaporation, the electrolyte films were vacuum dried for 12h, yielding films of $250\mu\text{m}$ thickness. The pre-active material $\text{Li}_x\text{V}_3\text{O}_8$ was prepared on the basis of sol-gel process. $\text{Li}_x\text{V}_3\text{O}_8$ gel was made following the procedure as described in Ref[6]. V_2O_5 (Aldrich Co.) was slowly added to a stirred LiOH (Aldrich Co.) aqueous solution at 60°C and stirred for 48h. Color of pre-active material was dark red gel. This gel was dried under vacuum at 200°C for 10h. The product was heated to 680°C and quench cooled to room temperature. $\text{Li}_x\text{V}_3\text{O}_8$ was ground and was vacuum dried at 200°C .

The conductivity of the PEO/PVDF electrolyte films was determined at 25, 40, 50, 60, 70 and 80°C , after equilibrium time of 30 min at each temperature. The area of symmetrical SUS/SPE/SUS cell was $2 \times 2 \text{ cm}^2$. The complex impedance of the polymer electrolyte was measured by the AC two electrode method using IM6 Impedance Measurement System(Zahner Elektrik Co.). The AC signal was applied across the cells and its frequency range was from 100mHz to 2MHz. The

conductivity of electrolyte films was calculated from Nyquist plot of complex impedance and the cell factor(film thickness/electrode area). Also, the transference number of electrolyte film was calculated by potentiostatic polarization method and AC impedance measurement of $\text{Li}/\text{SPE}/\text{Li}$ cell. Measurements were done with IM6 system.

Composite cathode slurry was prepared by mixing $\text{Li}_x\text{V}_3\text{O}_8$ powder with acetylene black and SPE solution. The mixture slurry was stirred for 3h. The composite cathode films were prepared by coating this slurry on Al foil current collector. After solvent evaporation, the composite films were vacuum-dried at 50°C for 4h. The area of $\text{Li}_x\text{V}_3\text{O}_8/\text{SPE}/\text{Li}$ cells was $2 \times 1 \text{ cm}^2$. Cyclic voltammetry was performed in the voltage range from 1.8V to 3.6V vs. Li/Li^+ using scan rate of 0.1mV/sec at 25°C . The current density of charge/discharge cycling was 0.05 and 0.1mA/ cm^2 . The complex impedance of $\text{Li}_x\text{V}_3\text{O}_8/\text{SPE}/\text{Li}$ cells was measured by the AC two electrode method using IM6 Impedance Measurement System(Zahner Elektrik Co.). Preparation and tests of cells were carried out in argon-filled glove box.

3. Results and discussion

Fig. 1 shows variation of conductivity of $\text{PEO}_x\text{PVDF}_y\text{LiClO}_4\text{PC}_z\text{EC}_5$ as a function of EO/Li^+ ratio. $\text{PEO}_x\text{PVDF}_y\text{LiClO}_4\text{PC}_z\text{EC}_5$ electrolyte exhibited higher conductivity with decreasing of EO/Li^+ mole ratio. However, the casting sample of $\text{PEO}_2\text{PVDF}_2\text{LiClO}_4\text{PC}_5\text{EC}_5$ electrolyte was like liquid. The ion conductivity of PEO/PVDF electrolytes was higher than that of PEO electrolyte without PVDF at room temperature. The variation of conductivity of PEO/PVDF electrolyte as a function of temperature was smaller than that of PEO electrolyte⁹. The conductivity of $\text{PEO}_4\text{PVDF}_4\text{LiClO}_4\text{PC}_5\text{EC}_5$ electrolyte was $5.2 \times 10^{-3} \text{ S/cm}$ at room temperature. At results, we suggest that the addition of high dielectric constant PVDF to the PEO- LiClO_4 -PC-EC electrolyte improved ion conductivity because of increase the dielectric

constant of electrolyte and weaken the association of the PEO-LiClO₄ complex.

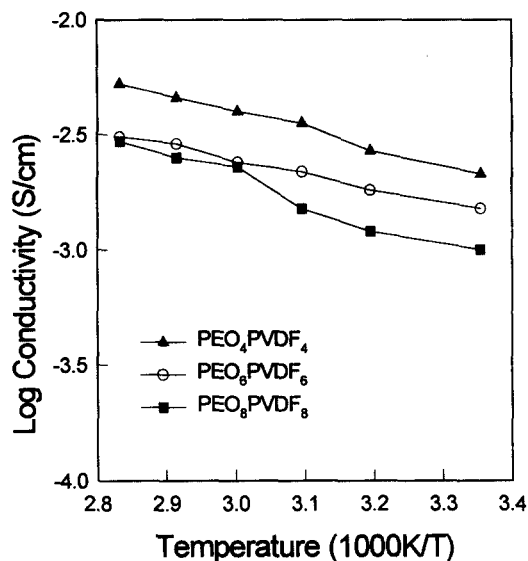

Fig. 1. Variation of conductivity of PEO_xPVDF_x LiClO₄PC₅EC₅ as a function of EO/Li⁺ ratio.

Fig. 2 exhibits result of potentiostatic polarization of Li/PEO₄PVDF₄LiClO₄PC₅EC₅/Li cell as a function of applied voltage. The polarization current with time was decreased with decreasing an applied voltage. The decrease of polarization current as a function of time seemed due to the polarization of the ClO₄⁻ ions because the lithium electrode is a non-blocking electrode for Li⁺ ions but a blocking electrode for the anion. The steady state current of polarization was observed within 60 minutes. The initial and steady currents of Li/PEO₄PVDF₄LiClO₄PC₅EC₅/Li cell with 10mV was 107uA and 77uA, respectively.

Fig. 3 shows impedance spectra of Li/PEO₄PVDF₄LiClO₄PC₅EC₅/Li cell as a function of polarization. The AC impedance response of Li/SPE/Li cell exhibited a progressive expansion of the middle frequency semicircle due to growth of passivation layer. The transference number of PEO₄PVDF₄LiClO₄PC₅EC₅ electrolyte was measured by polarization method and AC impedance

method described by M. watanabe¹⁰⁾. The t_+ is given by the equation¹¹⁾ (1).

$$t_+ = \frac{I_S(V - I_0R_0)}{I_0(V - I_S R_S)} \quad (1)$$

where V is the applied voltage. The measurement are taken at the initial values ($R=R_0$, $I=I_0$) and steady state values ($R=R_S$, $I=I_S$). The transference number t_+ of PEO₄PVDF₄LiClO₄PC₅EC₅ electrolyte was 0.3. The value of t_+ is lower

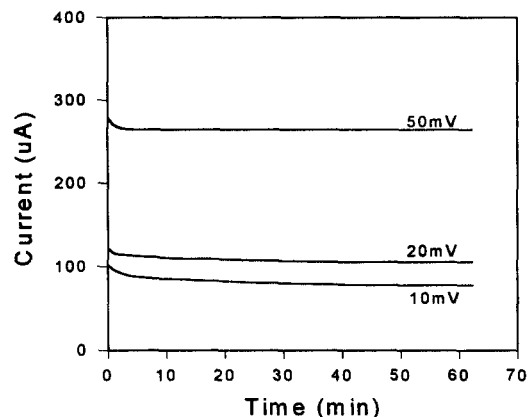

Fig. 2. Result of potentiostatic polarization of Li/PEO₄PVDF₄LiClO₄PC₅EC₅/Li as a function of applied voltage.

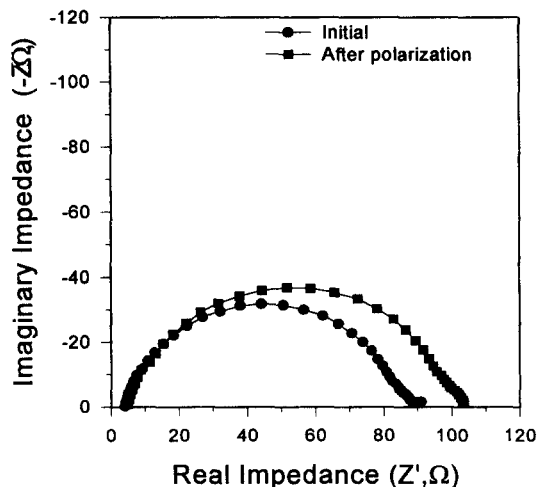

Fig. 3. Impedance spectra of Li/PEO₄PVDF₄LiClO₄PC₅EC₅/Li cell as a function of polarization.

than that of t_- . Further research will be studied PEO/PVDF electrolyte had the highest t_+ .

Fig. 4 shows cyclic voltammogram of $\text{Li}_x\text{V}_3\text{O}_8/\text{Li}$ cell. In the cyclic voltammogram for $\text{Li}_x\text{V}_3\text{O}_8$ composite cathode film, the reduction reaction of $\text{Li}_{1+x}\text{V}_3\text{O}_8$ showed three reduction peaks. Reduction

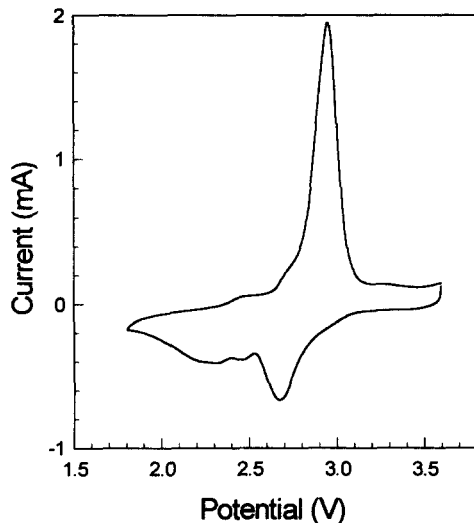

Fig. 4. Cyclic voltammogram of $\text{Li}_x\text{V}_3\text{O}_8/\text{SPE}/\text{Li}$ cell. (Scan rate : 0.1mV/sec)

peaks rised at 2.7, 2.45 and 2.35V. On the other hand, the oxidation peaks rised 2.45 and 2.9V.

The equivalent circuit representing the AC response of $\text{Li}_x\text{V}_3\text{O}_8/\text{SPE}/\text{Li}$ cell is given Fig. 5. The mobility of the lithium ion in polymer electrolyte is dominated by the resistor, R_b . The equivalent circle of Li/SPE interface is represented by a parallel combination of passivation layer resistance(R_f) and capacitance(C_f). The equivalent circuit elements of $\text{Li}_x\text{V}_3\text{O}_8/\text{SPE}$ consist of charge-transfer resistance(R_{ct}) for the Li^+ ion intercalation process, $\text{Li}_x\text{V}_3\text{O}_8$ composite resistance (R_c), double layer capacitance(C_{dl}) and Warburg impedance resulting from mass transport within $\text{Li}_x\text{V}_3\text{O}_8$ particles.

Typical AC impedance of $\text{Li}_x\text{V}_3\text{O}_8/\text{SPE}/\text{Li}$ cell is shown in Fig. 6. The bulk resistance of $\text{PEO}_4\text{PVDF}_4\text{LiClO}_4\text{PC}_5\text{EC}_5$ electrolyte was 6Ω . The impedance spectrum of $\text{Li}_x\text{V}_3\text{O}_8/\text{SPE}/\text{Li}$ cell

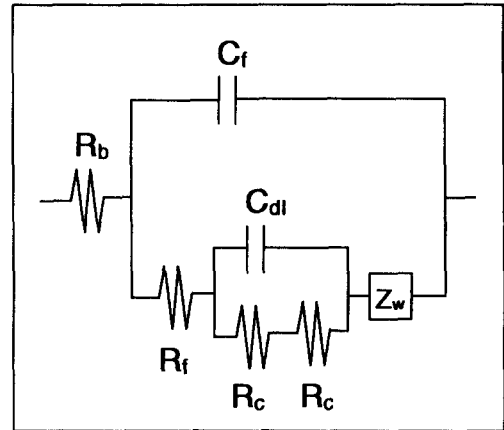

Fig. 5. Equivalent circuit of $\text{Li}_x\text{V}_3\text{O}_8/\text{SPE}/\text{Li}$ cell.

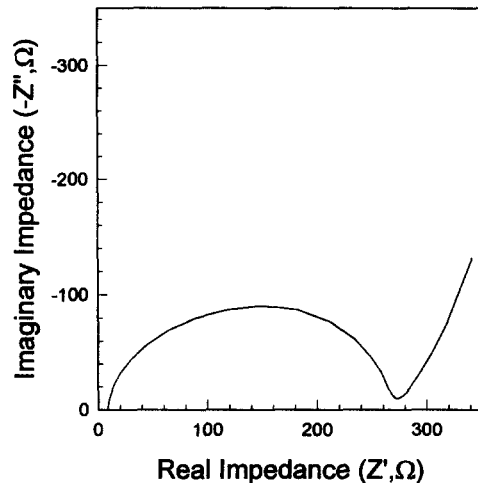

Fig. 6. Impedance plot of $\text{Li}_x\text{V}_3\text{O}_8/\text{SPE}/\text{Li}$ cell at 25°C.

consist of a semicircle in the frequency range of 60kHz ~ 1Hz and a line inclined to the real-axis in the frequency range of 1Hz ~ 10mHz. The semicircle represents the charge transfer process and composite cathode resistances of the $\text{Li}_x\text{V}_3\text{O}_8$ composite cathode film and of the passivation layer on the lithium electrode. The cell resistance was 270Ω .

Fig. 7 shows the first charge/discharge cycling curve of $\text{Li}_x\text{V}_3\text{O}_8/\text{SPE}/\text{Li}$ cell at room temperature. The initial open circuit voltage(OCV) of $\text{Li}_x\text{V}_3\text{O}_8/$

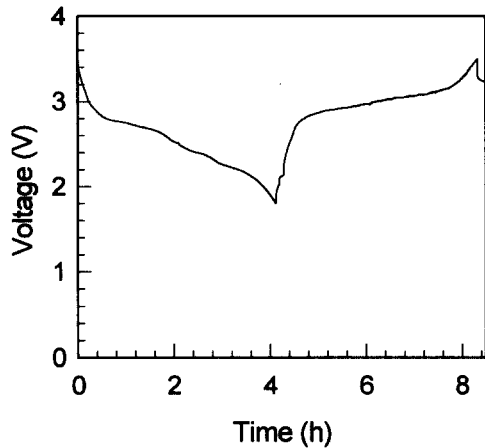

Fig. 7. First charge/discharge curve of $\text{Li}_x\text{V}_3\text{O}_8/\text{SPE}/\text{Li}$ cell.

(Current density : $0.1\text{mA}/\text{cm}^2$
Voltage range : $1.8\text{V} \sim 3.5\text{V}$)

SPE/Li cell was 3.57V . The charge/discharge cycling was carried out between 1.8V and 3.5V with current density of $0.1\text{mA}/\text{cm}^2$ at room temperature. The voltage variation as a function of Li^+ intercalation in $\text{Li}_x\text{V}_3\text{O}_8$ composite cathode correspond to the peaks in Fig. 4. The first discharge capacity based on $\text{Li}_x\text{V}_3\text{O}_8$ was $284\text{mAh}/\text{g}$. The Ah efficiency of 1st cycle was 96%.

Fig. 8 exhibits impedance spectra of $\text{Li}_x\text{V}_3\text{O}_8/\text{SPE}/\text{Li}$ cell

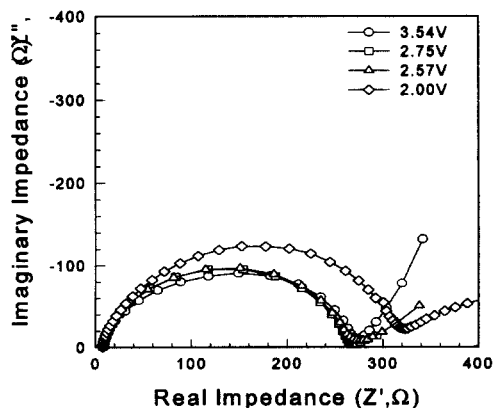

Fig. 8. Impedance spectra of $\text{Li}_x\text{V}_3\text{O}_8/\text{SPE}/\text{Li}$ cell as a function of SOC

SPE/Li cell as a function of state of charge(SOC). The resistance of $\text{Li}_x\text{V}_3\text{O}_8$ composite cathode during discharge process, intercalating lithium ions into $\text{Li}_x\text{V}_3\text{O}_8$, with various SOC was investigated. The radius of semicircle associated with the interfacial resistance of $\text{Li}_x\text{V}_3\text{O}_8/\text{SPE}/\text{Li}$ cell increased very slowly during discharge process from 3.54V to 2.57V . The cell resistance was 270Ω and 280Ω at 3.54V and 2.57V , respectively. On the other hand, the cell resistance of $\text{Li}_x\text{V}_3\text{O}_8/\text{SPE}/\text{Li}$ cell at 2.00V was high. The cell resistance was increased at discharge process from 10% SOC to 0% SOC. The increment of cathode resistance is attributed to increase of cell resistance during end discharge process.

Fig. 9 shows the specific capacity of $\text{Li}_x\text{V}_3\text{O}_8/\text{SPE}/\text{Li}$ cell as a function of charge/discharge cycling. The discharge capacity based on $\text{Li}_x\text{V}_3\text{O}_8$ of 1st and 15th cycles was $295\text{mAh}/\text{g}$ and $212\text{mAh}/\text{g}$ at current density of $0.05\text{mA}/\text{cm}^2$,

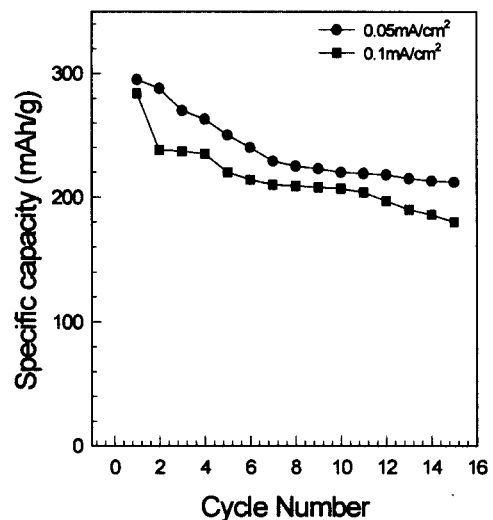

Fig. 9. Specific discharge capacity of $\text{Li}_x\text{V}_3\text{O}_8/\text{SPE}/\text{Li}$ cell at 25°C .

respectively. The Ah efficiency was above 98% at all cycles. The discharge capacity was decreased with charge/discharge cycling from 1st

cycle to 10th cycle. However, the capacity variation was not so clear after 10th cycle. From these results, we suggest that the sol-gel $\text{Li}_x\text{V}_3\text{O}_8$ heat-treated composite cathode showed good capacity with cycling.

4. Conclusions

On the basis of the results described above, one can reveal the following conclusions : The conductivity of $\text{PEO}_4\text{PVDF}_4\text{LiClO}_4\text{PC}_5\text{EC}_5$ electrolyte was $5.2 \times 10^{-3} \text{S/cm}$ at room temperature. The transference number t_+ of $\text{PEO}_4\text{PVDF}_4\text{LiClO}_4\text{PC}_5\text{EC}_5$ electrolyte was 0.3. The reduction reaction of $\text{Li}_{1-x}\text{V}_3\text{O}_8$ showed three reduction peaks. The resistance of pure $\text{Li}_x\text{V}_3\text{O}_8/\text{SPE}/\text{Li}$ cell was 270Ω . The discharge capacity based on $\text{Li}_x\text{V}_3\text{O}_8$ was 284mAh/g . The radius of semicircle associated with the interfacial resistance of $\text{Li}_x\text{V}_3\text{O}_8/\text{SPE}/\text{Li}$ cell increased very slowly during discharge process from 3.54V to 2.57V . And then the cell resistance was increased at discharge process from 10% SOC to 0% SOC. The discharge capacity based on $\text{Li}_x\text{V}_3\text{O}_8$ of 1st and 15th cycles was 295mAh/g and 212mAh/g .

Acknowledgement

This Paper was supported by Non-Directed Research Fund, Korea Research Foundation, 1996.

References

1. J. R. MacCallum and C. A. Vincent : Polymer Electrolyte Reviews I, Elsevier Applied Science, New York, pp. 1-15, 1987.
2. K. Murata and K. Takeuch, "Development of Solid Polymer Electrolyte and Its Applications", Yuasa-Jiho, No. 71, pp. 4-12, 1991.
3. T. Takahashi, "古體イオニクス", 應用物理, 49卷1, 10號., pp. 956-974, 1980.
4. K. M. Abraham and M. Alamgir, "Ambient Temperature Rechargeable Polymer electrolyte Batteries", J. Power Source, Vol. 43-44, pp. 195-208, 1993.
5. K. M. Abraham, "Directions in Secondary Lithium Battery Research and Development", *Electrochimica Acta*, vol. 38, No. 9, pp. 1233-1248, 1993.
6. K. West, Y. Saide, J. Barker, B. Zach Christensen, I. I. Olsen, R. Pynenburg, S. Skaarup, R. Koksang, "Comparison of LiV_3O_8 Cathode Materials Prepared by High Temperature and Gel Synthesis", *The Electrochemical Society Proceedings Volume 94-28*, pp. 286-296, 1994.
7. K. West, B. Zachau-Christiansen, S. Skaarup, J. Barker, I. I. Olsen, R. Pynenburg, and R. Koksang, "Comparison of LiV_3O_8 Cathode Materials Prepared by Different Methods", *J. Electrochem. Soc.*, Vol. 143, No. 3, pp. 820-825, 1996.
8. Aishui YU and Naoake KUMAGAI, "Characterization of Two Modified Lithium Vanadate Cathode Materials in Secondary Lithium Batteries", *Electrochemical Society Proceedings Volume 97-18*, pp. 215-232, 1997.
9. J. U. Kim, B. S. Jin, S. I. Moon, H. B. Gu and M. S. Yun, *Proceeding of summer symposium on the Korea Institute of Electrical Engineers*, Vol. C, pp. 1229-1232, 1994.
10. M. Watanabe, K. Sanui and N. Ogata, "Ionic Conductivity and Mobility in Network Polymers from Poly(propylene oxide) containing Lithium Perchlorate", *J. Appl. Phys.* Vol. 57, pp. 123-128, 1985.
11. J. Evans et al., "Electrochemical measurement of transference numbers in polymer electrolytes", *POLYMER*, Vol. 28, PP. 2324-2328, 1987.
12. Jong-Uk Kim, In-Seong Jeong, Ju-Seung Kim, Gye-Choon Park, Katsumi Yoshino and Hal-Bon Gu, "Electrochemical Properties and Application of PEO/PVDF Electrolytes for All-solid State Lithium Rechargeable Battery", *Proceedings of International Solar Energy Society Solar World Congress*, Vol. 3, pp. 51-59, 1997.
13. Jong-Uk Kim, Chang-Ho Sung and Hal-Bon Gu, "Charge/discharge and Interfacial Properties of $\text{Li}_x\text{V}_3\text{O}_8/\text{Li}$ Cells with Polymer Electrolyte", 1997 IEEE Annual Report, Vol. 1, pp. 190-193, 1997.