

Effects of Surface Order Parameter on Polar Anchoring Energy in NLC on Weakly Rubbed Polyimide Surface

Dae-Shik Seo

Abstract

We have investigated the relationship between the polar anchoring energy and the surface order parameter in nematic liquid crystal (NLC), 4-n-pentyl-4-cyanobiphenyl (5CB), on the two kinds of the weakly rubbed polyimide (PI) surfaces. The observed polar anchoring energy of 5CB is approximately 2×10^{-4} (J/m²) and then increases with increasing the rubbing strength (RS) on weakly rubbed surface (RS=57mm) with side chain at 30°C; same results are obtained on weakly rubbed PI surface without side chain. The surface order parameter of 5CB on rubbed PI surfaces increases with increasing the RS at a weak rubbing region. The surface order parameter of 5CB is strongly related to the characteristics of PI material. Consequently, we suggest that the polar anchoring energy of NLC is strongly attributed to the surface order parameter on rubbed PI surfaces.

Key Words : Nematic liquid crystal (NLC), Polyimide surface, Rubbing strength, Polar anchoring energy, Surface order parameter

1. INTRODUCTION

Nowadays, twisted nematic (TN) liquid crystal display (LCD) devices are widely utilized for the information displays. Uniform alignment of LCs on substrate surfaces is an important matter from scientific viewpoint as well as technological viewpoint. Interfacial properties between the LCs and the alignment surfaces are key to understand the alignment mechanism of LCs. Rubbed polyimide (PI) surfaces have been widely used to align LC molecules.

Previously, the polar anchoring energy between the LCs and the alignment layers on treated substrate surfaces has been demonstrated and discussed by some reserachers.¹⁻⁵⁾ In a previous work, we reported the first measurement of the temperature dependence of the polar

(out-of-plane tilt) anchoring strength of weakly rubbed PI surfaces in 5CB.³⁾ We also reported the temperature dependence of the polar anchoring strength of 5CB on various PI-LB surfaces.^{6,7)} In this paper, we report the relationship between the polar anchoring strength and the surface ordering in NLC, 5CB, on rubbed PI surfaces.

2. EXPERIMENTAL

The molecular structure of the used two kinds of the polymer material is shown in Figure 1. The PI films were coated on indium-tin-oxide (ITO) coated glass substrates by spin-coating, and were imidized at 250°C for 1 hr. The thickness of PI layers was about 500Å. The PI films were rubbed using a machine equipped with a nylon roller (Y₀-15-N, Yoshikawa Chemical Industries Co., Ltd.). The definition of the

* : 숭실대학교 전기공학과
(서울시 동작구 상도 5동 1-1, Fax: 02 817-7961
E-mail : dsseo@elec.pwr.soongsil.ac.kr)
1993년 9월 10일 접수, 1998년 10월 28일 심사완료

rubbing strength, RS was given in previous papers.^{8,9)} LC cells were assembled with the antiparallel to rubbing direction. The LC layer thickness was set at $60 \pm 0.5 \mu\text{m}$. We investigated the anchoring strength by using "high electric-field techniques".^{1,2} We measured the optical retardation (R) and the electric capacitance (C) as a function of applied voltage (V) in order to determine the polar anchoring strength. Figure 2 shows the measurement system of the anchoring strength. The optical retardation measurement system consists of a polarizer, an acousto-optic modulator, and an analyzer. The output signal is detected by a photodiode. The electric capacitance of the LC cell is obtained by measuring the out-of-phase component of the current produced by changing the voltage which is applied to the cell. The extrapolation length d_e is determined by using the relationship between the measured values of the electric capacitance and the optical retardation :

$$\frac{R}{R_0} = \frac{I_0}{CV} \cdot \frac{2d_e}{d} \quad \text{when } V \gg 6V_\mu \quad (1)$$

where I_0 is a proportional constant depending on the LC materials; V and d stand for the applied voltage and LC medium thickness, respectively.

The polar anchoring energy A is obtained from following relation:

$$A = \frac{K}{d_e} \quad (2)$$

where K is the effective elastic constant which is given by $K = K_1 \cos^2 \theta_o + K_3 \sin^2 \theta_o$, where K_1 , K_3 , and θ_o stand for the elastic constant of the splay and bend deformation, and the pretilt angle, respectively. We used the measured elastic constants in this work. The surface order parameter was measured by measuring the optical retardation induced on the substrate surface above the nematic-isotropic transition temperature T_c .¹⁰

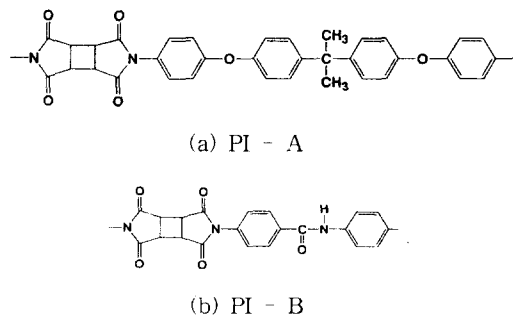

Fig. 1. Used polymer molecular structure.

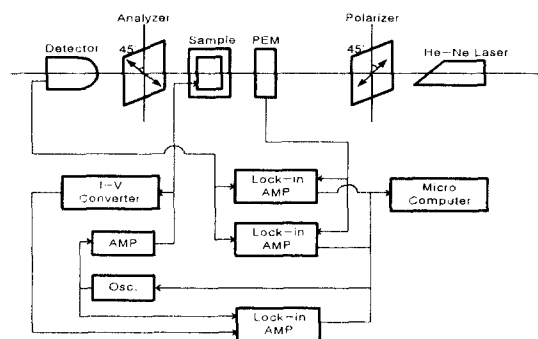
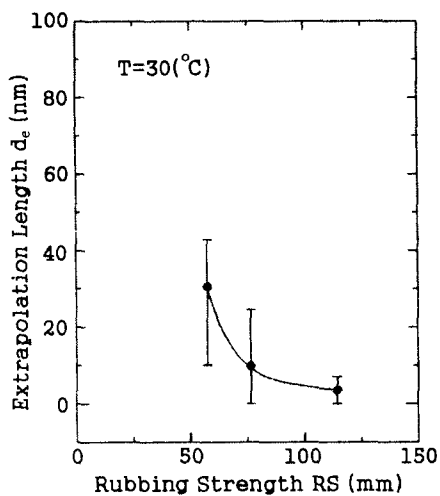

Fig. 2. Measuring system of polar anchoring strength.

3. RESULTS AND DISCUSSION

The dependence of the rubbing strength of the extrapolation length in 5CB on weakly rubbed PI surface are shown in Figure 3 (a) and (b). It is shown that the extrapolation length of 5CB decreases with increasing the RS on rubbed PI-A surface with side chain. The same results are obtained on rubbed PI-B surface without side chain. From these results, we can consider that the extrapolation length of 5CB is decreased due to more surface ordering with increasing the RS.

Figure 4 (a) and (b) shows the dependence of the rubbing strength of the polar anchoring energy in 5CB on weakly rubbed PI-A surface with side chain. It is shown that the polar anchoring energy of 5CB is approximately $2 \times 10^{-4} \text{ (J/m}^2\text{)}$ at a very weakly rubbed PI surface (RS=57mm) and then increases with increasing



(a) PI - A

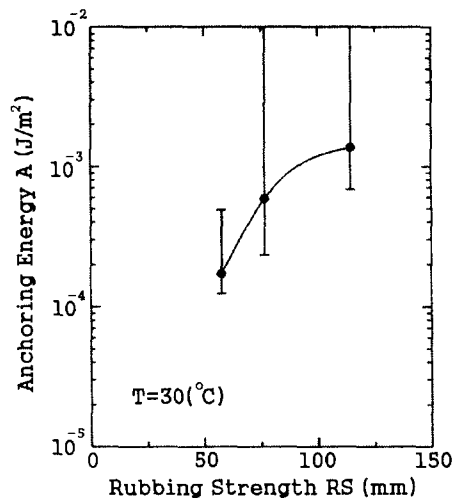

(a) PI - A

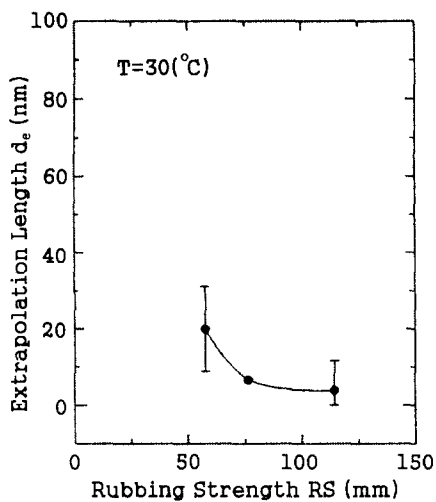

(b) PI - B

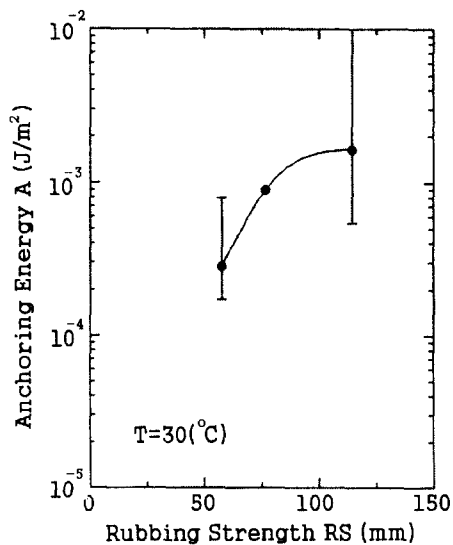

(b) PI - B

Fig. 3. Dependence of the rubbing strength of the extrapolation length in 5CB on weakly rubbed PI surface

Fig. 4. Dependence of the rubbing strength of the polar anchoring strength in 5CB on weakly rubbed PI-A surface with side chain.

the RS. The observed polar anchoring energy of 5CB is about 1×10^{-3} (J/m²) at a weak rubbing region (RS=114mm); it is increased about 1×10^{-1} (J/m²). The same effects are observed on weakly rubbed PI-B surface without side chain as shown in Figure 4 (b). It is considered that the anchoring energy of 5CB strongly depends on the RS.

Figure 5 (a) and (b) shows the residual retardation induced on two kinds of the weakly rubbed PI surfaces as a function of temperature

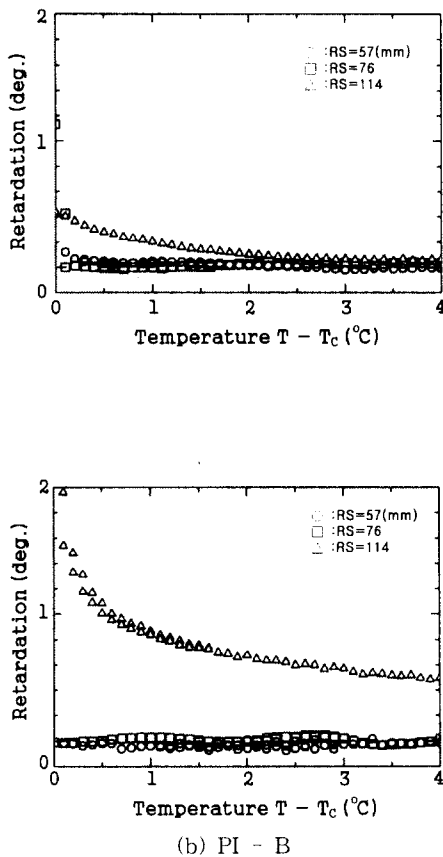

Fig. 5. Residual optical retardation induced on two kinds of the weakly rubbed PI surfaces as a function of temperature above the clearing temperature T_c

above the clearing temperature T_c . The residual optical retardation of 5CB is almost 0 at a very

weak RS for RS=57mm and RS=76mm and then increased at a RS=114mm on weakly rubbed PI-A surface with side chain as shown in Figure 5 (a). In figure 5 (b), the residual retardation induced of 5CB is almost 0 at weak RS for RS=57mm and RS=76mm and then more increased at RS=114mm on weakly rubbed PI-B surface without side chain. Figure 6 shows the surface order parameter of 5CB on two kinds of the rubbed PI surfaces as a function of RS. It is shown that the surface order parameter of 5CB increases with increasing the RS at a weak RS region and then saturates above the RS=189mm on rubbed PI-A surface with side chain. The high surface order parameter of 5CB is obtained above the RS=189mm; it indicates to be very stable. It is considered that the surface ordering of 5CB increased due to the increase of LC aligning capability with increasing the RS. The surface order parameter of 5CB increases with increasing the RS at a weak RS region and then approached peak point, and then decreases with increasing the RS. These behaviours are different compared with the PI-A surface with side chain. It is considered that the surface order parameter of 5CB is strongly attributed to the

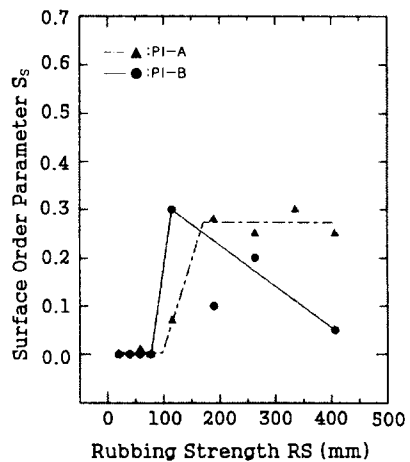

Fig. 6. Surface order parameter of 5CB on two kinds of the rubbed PI surfaces as a function of RS.

characteristics of PI materials. Consequently, we can suggest the polar anchoring energy of NLC strongly depends on the surface order parameter.

4. CONCLUSION

In summary, the good relationship between the polar anchoring energy and the surface order parameter was obtained. The polar anchoring energy of 5CB is about 2×10^{-4} (J/m²) and then increases with increasing the RS on weakly rubbed surface with side chain at 30°C; same results are obtained on weakly rubbed PI surface without side chain. The surface order parameter of 5CB on rubbed PI surfaces increases with increasing the RS at a weak rubbing region. The surface order parameter of 5CB is strongly related to the characteristics of PI material. Consequently, we suggest that the polar anchoring strength of NLC is strongly attributed to the surface order parameter on rubbed PI surfaces.

References

1. H.Yokoyama, "Surface anchoring of nematic liquid crystals", *Mol.Cryst. Liq. Cryst.*, Vol. 165, 269-316 (1988).
2. H. Yokoyama and H.A. van Sprang, "Novel method for determining the anchoring energy function at a nematic liquid crystal-wall interface from director distortions at high fields", *J.Appl.Phys.*, Vol. 57, 4520-4526 (1985).
3. D.-S.Seo, Y.Iimura, and S.Kobayashi, "Temperature dependence of the polar anchoring strength of weakly rubbed polyimide films for the nematic liquid crystal (5CB)", *Appl.Phys. Lett.*, Vol. 61, 234-236 (1995).
4. D.-S. Seo, N. Yoshida, S. Kobayashi, M. Nishikawa, and Y. Yabe, "Effects of conjugation of mesogenic core of nematic liquid crystals for polar anchoring energy and surface order parameter on rubbed polyimide films", *Jpn. J. Appl. Phys.*, Vol. 33, L1174- L1177 (1994).
5. D.-S. Seo and S.Kobayashi, "Effect of high pretilt angle for anchoring strength in nematic liquid crystal on rubbed polyimide surface containing trifluoromethyl moieties", *Appl.Phys.Lett.*, Vol. 66, 1202-1204 (1995).
6. D.-S. Seo, S. Kobayashi, D.-Y. Kang, and H. Yokoyama, "Effects of rubbing and temperature dependence of polar anchoring strength of homogeneously aligned nematic liquid crystal on polyimide Langmuir-Blodgett orientation films", *Jpn.J.Appl.Phys.*, Vol. 34, 3607-3611 (1995).
7. D.-S.Seo, S.Kobayashi, M.Nishikawa, J.-H.Kim, and Y.Yabe, "Odd-even effects of the polar anchoring strength in nematic liquid crystal on rubbed polyimide Langmuir-Blodgett films with alkyl chain lengths", *Appl.Phys.Lett.*, Vol. 66, 1334-1336 (1995).
8. D.-S.Seo, K.Muroi, and S.Kobayashi, "generation of pretilt angle in nematic liquid crystal, 5CB, media aligned polyimide films prepared by spin-coating and LB techniques : effect of rubbing", *Mol.Cryst.Liq.Cryst.*, Vol. 213, 223-228 (1992).
9. D.-S.Seo, S. Kobayashi, and M. Nishikawa, "Study of the pretilt angle for 5CB on rubbed polyimide films containing trifluoromethyl moiety and analysis of the surface atomic concentration of F/C(%) with an electron spectroscope for chemical analysis", *Appl.Phys.Lett.*, Vol. 61, 2392-2394 (1992).
10. K.Miyano, "Surface-induced ordering of a liquid crystal in the isotropic phase", *J. Chem. Phys.*, Vol. 71, 4108-4111 (1979).